



# VIC Leak Detection

## Air Leak Testing



**2100 Series**  
Mass Flow Leak Detectors

# 2100 Series

## Pneumatic Leak Detectors

### Applications

- Brake calipers
- Air brake components and systems
- Castings: aluminum, steel, magnesium
- Exhaust systems: mufflers, catalytic converters, Y-pipes, assemblies, etc.
- Medical components: catheters, syringes, etc
- Radiators
- Oil Coolers
- Faucets
- Gearboxes, gear housings
- Connectors: fuel line, oil cooler, etc
- Refrigerator water and ice dispensers
- Air operated nailer guns
- Complete engine cavities
- Air conditioning and heating components: evaporators, heater cores
- Valves
- Copier toner cartridges
- Burial caskets
- Oil pumps
- Cylinder heads
- Fuel system components

*Questions about your application? Please contact our Sales Department*

### Simple. Fast. Easy. Leak and flow restriction testing technology from VIC Leak Detection gets accurate, reliable results—everytime.

The Air Leak Testing division of VIC Leak Detection, the world leader in leak detection technology, specializes in leak and flow restriction testing that streamlines the leak detection process while increasing manufacturing productivity. Each Air Leak Testing instrument contains the patented, ultra-fast-response thermal mass flow meter that is optimized to perform with a very low pressure. This makes our mass flow technique ideally suited for high-throughput leak test applications.

The 2100 Series offers versatile, easy-to-use pneumatic leak detectors designed for industrial or laboratory environments. Two models are available: The Model 2110 Benchtop is compact and easily portable, while Model 2120 utilizes a NEMA-12 enclosure for harsh industrial environments.

#### The mass flow technique makes the 2100 Series inherently superior

- ★ Test results in engineering units are not dependent upon operator judgment
- ★ Dry testing eliminates contamination due to immersion
- ★ Direct leak rate readout is independent of part volume

#### Standard features include

- ★ Mass flow leak detection technique optimizes testing under all conditions. It speeds testing and assures minimum cycle time while it is self adjusting with temperature changes. Parts cannot be over pressurized
- ★ Menu prompted keypad display allows easy test setup, test status and diagnostics monitoring/indication
- ★ Automatic setup establishes all non-calibration related parameters. The operator simply loads a part then presses the start button and the test parameters are automatically determined and stored. Generates and stores unique parameters that are checked with each test to assure parts are properly tested under any conditions

- ★ Patented thermal mass flow sensor assures ultimate performance
- ★ Patented fill process optimizes test cycle time and eliminates any need for multiple calibration setups

#### Test parts of varying sizes with no change in setup

- ★ Self-contained pneumatics package with pilot operated valving
- ★ "Early Kick-Out" test mode saves substantial cycle time compared with other methods
- ★ Multiple part selection library for quick changeover of multiple part numbers and associated parameters
- ★ SPC data collection with individual part or batch reporting. Test readings can be transmitted with each test or stored and periodically downloaded
- ★ Clamp mechanism control output
- ★ Ideal for automated testing. 2100 Series leak detectors communicate with host PLC for unattended, trouble-free operation
- ★ NIST Traceable Calibration Certification

*The industry standard in leak*

**2100 Series Leak Detectors are especially easy-to-use**

Simply program the desired leak reject level and cycle a known good part. The unit will automatically establish all pertinent settings and you are ready for production testing:



**SPC Data Screen**

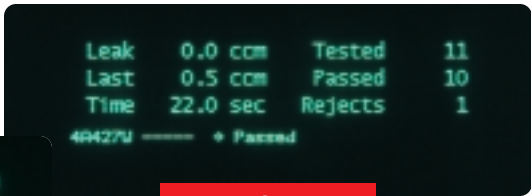

**Run Screen**

**Mass Flow Leak Test**

1. Open Fill and Test Valves: Part is pressurized
2. Close Fill Valve: All make-up air now flows through transducer
3. Monitor stabilizing air flow reading for leak rate

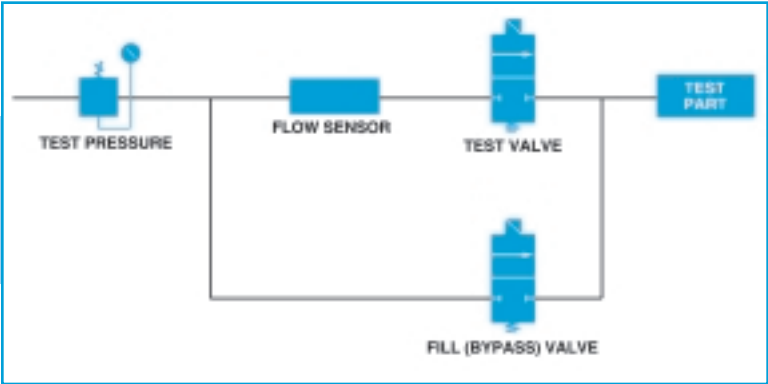

**For applications that require pressure decay testing, the 2100 Series can be configured two ways**

- Single Ended (P type): pressure ranges 0-1, 0-5, 0-50, 0-100, 0-500 psig, 0-25 in. Hg Vacuum; 24 Bit A/D for 0.00005 psi resolution, sensor accuracy 0.25% FS and proof pressure 200% of full scale
- Differential Pressure (D type): heavy duty differential pressure transducer with over-pressure protection; pressure ranges 0-1, 0-5, 0-50, 0-100, 0-500 psig, 0-25 in. Hg Vacuum; 24 Bit A/D Converter for 0.00001 psi resolution, sensor accuracy 0.5% FS.

**Options and Accessories**

- Additional Test Pressure and Leak Rate Ranges
- Model PH1NV Adjustable Metering Valve
- Model LD20 Digital Leak Rate Calibrator
- Calibrated Leak Orifice
- Air Piloted and Manually Operated Leak Test Seals and Connectors
- Turnkey Leak Detection and Flow Restriction Test Systems customized to your specific needs

**Ordering Information**

Please specify:

- **Model 2110** Laboratory Benchtop or
- **Model 2120** NEMA

Please also specify:

- **Full scale test pressure** and
- **Full scale leak rate range**
- **Pressure decay (P)**
- **Differential pressure (D)**

Example:

**Model 2110, 100 sccm FS @ 0-60 psig**



*Vacuum Instrument Corporation has the broadest experience, and the most comprehensive leak detection solutions required to design, build, sell, and service the most innovative leak detectors anywhere in the world. That is because leak detection is and always has been our only business. We are dedicated to leak detection, and our customers have made us the largest leak detector company in the world.*



**VIC Leak Detection**

Industrial Leak Detection  
Air Leak Testing  
Vacuum Metrology

*detection...*

<b>Performance</b>	2100 Series Leak Detector Specifications
Leak Rate Ranges	0~10, 0~50, 0~100, 0~500 sccm 0~1, 0~5, 0~10, 0~50, 0~100 slpm 0~1, 0~5, 0~10, 0~50 scfm
Pressure Ranges	0~1, 0~5, 0~30, 0~60, 0~100 psig 0~10, 0~100 in. wc 0~25 in. Hg Vacuum
Test Method	Mass flow technique with direct readout in leak rate
SPC Data Collection	Counters for parts tested, accepted and rejected; individual test report with part number, leak rate reading, time and date; batch report with part number total tested, accepted, rejected, average, minimum, maximum, range, standard deviation and time and date stamp; reports transmitted via integral RS 232C port
<b>Transducer</b>	Temperature compensated thermal mass flowmeter:
Accuracy	±1% FS
Repeatability	±0.1% FS
Response Time	60 mSec time constant
Pressure Drop	Maximum 1inch wc at full scale leak rate
Temperature Range	50~110°F
Control Inputs	Optically isolated inputs include Start and Reset
Control Outputs	Optically isolated outputs, 1A max. Specify 5~60 VDC or 12~280 VAC operation. Outputs include End of Test, Go/No-Go, Diagnose and Clamp Control
Calibration	N.I.S.T. traceable calibration with certification
Keypad	Membrane keypad with alphanumeric data entry
Display	4 line x 40 character blue-green vacuum fluorescent display
<b>Enclosure</b>	
Model 2110	11" h x 19" w x 15" d Benchtop enclosure with bale/handle
Model 2120	20" h x 16" w x NEMA-12 enclosure
Weight	25 kilograms (55 pounds)
Air Supply	Clean, dry compressed air, 30 psig above test pressure, 95% max R.H., oil-free
Electrical Power	115/230 VAC, 50~60 Hz, 350 VA

*Specifications are subject to change without notice.*

## 2100 Series Mass Flow Leak Detectors

- Test results in engineering units are not dependent on operator's judgment
- Dry testing eliminates contamination due to immersion
- Direct leak rate readout is independent of part volume
- Automatic Setup establishes all non-calibration related parameters
- Patented thermal mass flow sensor assures ultimate performance
- Patented fill process optimizes test cycle time and eliminates any need for multiple calibration setups
- Can be configured in single ended or differential pressure decay versions where a pressure decay test is required

Model 2100 Dual Station Filler Pipe Leak Test Stand



### VIC Leak Detection

Industrial Leak Detection  
Air Leak Testing  
Vacuum Metrology

#### Vacuum Instrument Corporation

2099 Ninth Avenue, Ronkonkoma, New York 11779 USA  
Tel 631.737.0900 • Fax 631.737.1541  
www.vacuuminst.com • vicsales@vacuuminst.com

#### Air Leak Testing Division

3203 Plainfield Road, Dayton, Ohio 45432 USA  
Tel 937.253.7377 • Fax 937.253.3877  
www.vacuuminst.com • vicsales@vacuuminst.com

#### Sales/Service Offices

California, Indiana, Michigan, New York, Ohio,  
Mexico, United Kingdom, France, Germany, Japan

Exclusive Sales & Service Representatives Worldwide